

DIGITAL FILE SPECIFICATION CPI EASTBOURNE & BOGNOR (POD)

2024

CPI Eastbourne (POD)

48-50 Birch Close,
Eastbourne, East Sussex, BN23 6PE
T: +44 (0)13 2343 4700



DIGITAL FILE SPECIFICATION CPI EASTBOURNE & BOGNOR (POD)

2024

Contents

- 42** Guidelines for supplying text files

- 43** Guidelines for supplying illustration files

- 44** Guidelines for supplying colour digital files

- 53** Font guidelines

- 54** Jacket and printed paper case layouts

- 55** Flapped paperback and flexi bind layouts

- 56** Spine brass file settings

Text File Guidelines

Digital data

We accept PDFs or Application Files. All files can be supplied via CPI Highway, FTP, email or by using a web based file transfer service. For PDFs, please embed all fonts and use high resolution images. PDF files must be supplied 'upright' with no rotation required. If you wish to supply Application Files, please contact your Customer Service Executive for more information on our pre-press services and a full list of prices. Before submitting any digital data, please ensure you have read this guide fully.

Data format

When exporting your file to PDF, please embed all fonts and DO NOT subset, DO NOT use security settings, DO NOT downsample images and DO NOT apply any colour profiles to the PDF on creation.

Other Requirements

- When creating a PDF it is preferred that it is supplied with
- 10mm area all the way around the document. This will include cutmarks and job bleeds.
- When printing double page spreads please pull out the image area from the spine by up to 4mm on the first / last leaf of book or 2mm on other pages, this will ensure readers do not break the spine of the book to read the full spread.
- Files must contain a trim box set to the trim size. All PDF pages must have the same trim box information.
- Text pages should be supplied as single pages not double-page-spreads and combined within one PDF.
- Text pages to be supplied as: Mono – 100% Black.
- Text pages should not be supplied as RGB, nor should there be any layers or transparencies. As transparencies are on-screen effects only, they have no effect on the final printed image and will automatically be stripped out by our prepress systems. Any image adjustments should be made prior to PDF creation, transparencies should not be used.
- Halftones should be supplied at a maximum of 60% to reduce set-off and ink drag where these halftones bleed.
- Where multiple images bleed at head and foot there is a risk of ink drag during binding. This can be resolved by sanding copies after binding (additional cost applies)
- All files should be supplied at the correct size. Should enlargements or reductions be required, this should apply to the whole job.
- Re-supplied / corrected files should contain updated information within the naming convention of the file ie. Job Title_Page Number_Revision Number. They should also be supplied the same size and offset as previous.
- There should be no copy within 6mm of the trim including non bleeding text within tint panels.
- When supplying marked-up pages to be corrected, ensure corrections required are clearly marked.
- Please allow a minimum bleed area of 3mm where necessary.
- Printers details on the imprint page should read:
Printed and bound by CPI Group (UK) Ltd, Croydon, CR0 4YY

Illustrations File Guidelines

Digital data

We accept PDFs or Application Files. All files can be supplied via CPI Highway, FTP, email or by using a web based file transfer service. For PDFs, please embed all fonts and use high resolution images. PDF files must be supplied 'upright' with no rotation required. Do not leave errors uncorrected and ensure a colour proof is supplied for content. If you wish to supply Application Files, please contact your Customer Service Executive for more information on our pre-press services and a full list of prices. Before submitting any digital data, please ensure you have read this guide fully.

Data format

When exporting your file to PDF, please embed all fonts and DO NOT subset, DO NOT use security settings, DO NOT downsample images and DO NOT apply any colour profiles to the PDF on creation.

Halftones/images

To be CMYK or greyscale @ 300dpi or above. Linework to be Bitmap Tiff @ 600 dpi or below (do not convert greyscales to Bitmap Tiffs if they are lower than specified resolution and always convert using the '50%threshold' setting.

Other Requirements

- When creating a PDF it is preferred that it is supplied with 10mm area all the way around the document. This will include cutmarks and job bleeds.
- All files should be supplied at the correct size. Should enlargements or reductions be required, this should apply to the whole job.
- Re-supplied / corrected files should contain updated information within the naming convention of the file ie. Job Title_Page Number_Revision Number. They should also be supplied the same size and offset as previous.
- When supplying marked-up pages to be corrected, ensure corrections required are clearly marked.
- Pages should be supplied as single pages not double page spreads.
- Please allow a minimum bleed area of 3mm where necessary.
- Files must contain crop marks. These are to be offset by 4mm.
- Files must contain a trim box set to the trim size.
- All PDF pages must have the same trim box information.

Digital Colour Files

Digital data

We accept PDFs or Application Files. All files can be supplied via CPI Highway, FTP, email or by using a web based file transfer service. For PDFs, please embed all fonts and use high resolution images. PDF files must be supplied 'upright' with no rotation required. Ensure trim and spine marks are included and do not leave errors uncorrected. A colour proof should be supplied for content. All colour files should be supplied combined as one PDF including spot colours. If you wish to supply Application Files, please contact your Customer Service Executive for more information on our pre-press services and a full list of prices. Before submitting any digital data, please ensure you have read this guide fully.

Data format

When exporting your file to PDF, please embed all fonts and DO NOT subset, DO NOT use security settings, DO NOT downsample images and DO NOT apply any colour profiles to the PDF on creation.

Halftones/images

To be CMYK or grayscale @ 300dpi or above (layered files preferred if available Linework to be Bitmap Tiff @ 600 dpi or below (do not convert grayscales to Bitmap Tiffs if they are lower than specified resolution and always convert using the '50%threshold' setting.

PDF Samples

CPI recommend maximum ink cover of 240% on coated materials CPI recommend maximum ink coverage of 200% on uncoated materials (including inners of covers).

*Please note * TAC value for every paper is different, and range can alter between 80% to 240%**

Colour Digital Files

To create a new job in InDesign the page size must match the desired trimmed book size eg: A Cover made up with a 198mm x 129mm board size and a 30mm spine will be 288mm in width by 198mm in depth.

$$129\text{mm Back cover} + 30\text{mm Spine} + 129\text{mm Front cover} = 288\text{mm}$$

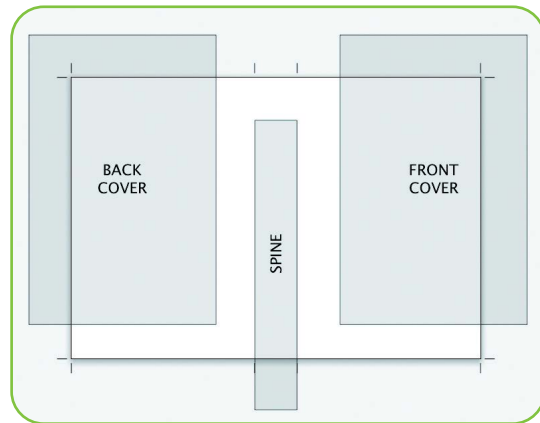
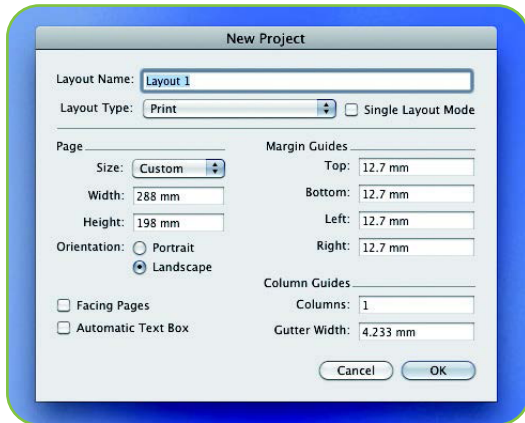

When assembling a document the picture boxes must include the board sizes and bleed which is normally unless instructed 3mm.

The bleed is extra image on the side of a document that ensures that no unprinted edges occur in the final trimmed document.

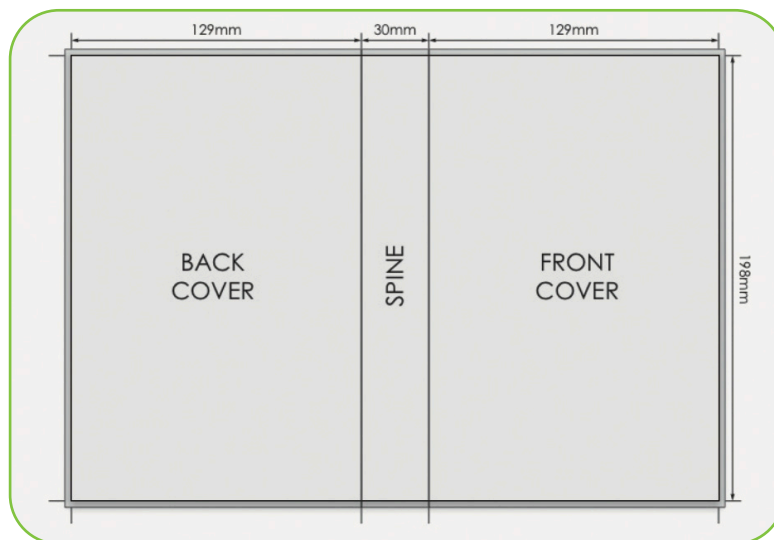

For example: $129\text{mm} + 3\text{mm} = 132\text{mm}$ width

$198\text{mm} + 3\text{mm top} \& 3\text{mm bottom} = 204\text{mm}$ depth.

When positioning picture boxes in InDesign they must butt up against each other to eliminate gaps in the printing. If this is not done correctly it will normally result in a white line showing.

For example: A 129mm Picture box used as a back cover with 3mm bleed will be 132mm in width. 3mm of this box will be outside the document area for bleed so the next Picture box used for the spine will start at a position of 129mm.

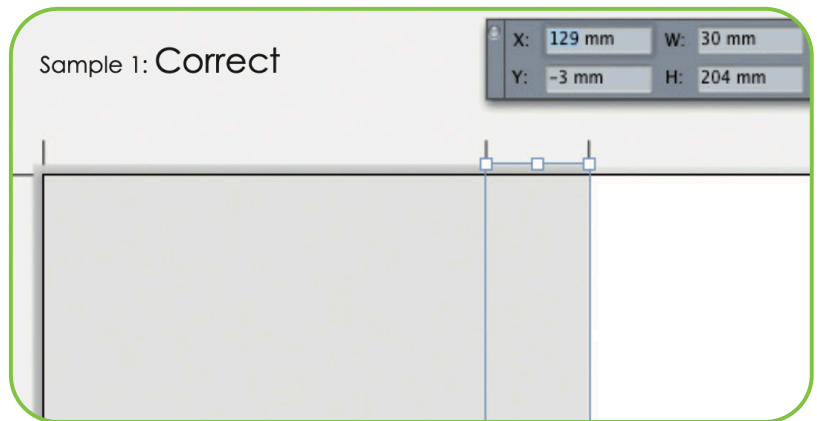

As you can see from the incorrect version there is a white gap between the two image boxes which would show when printed. This is a result of the Picture box not starting at the 129mm coordinate as in the correct sample 1.

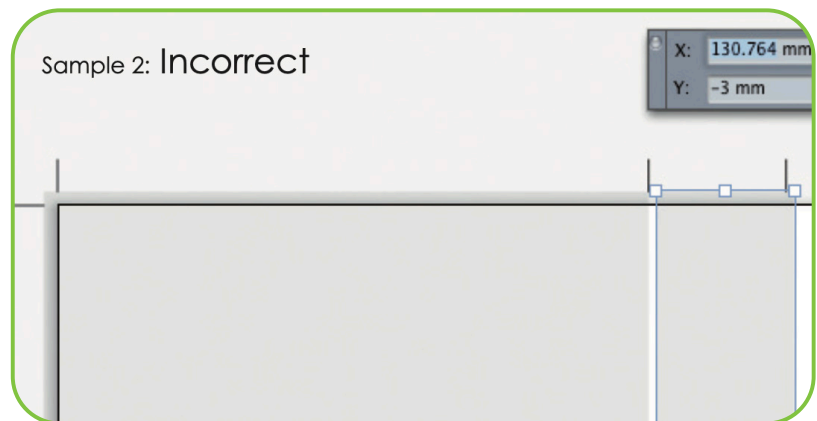

Inner Component Printing

When a Cover or Jacket has inner printing it should match the outer files exactly for dimensions and layout. For example the same board size and spine size etc. This is very important so when the files get printed the Inners back up to the outer printing on press.

It is standard practice that the spine is left white / has no ink printed on it +1.5mm either side for standard 2 score bound work or +3mm either side for 4 score work. This allows for the glue to adhere to the cover when the books are assembled. Ink densities should also on the inner be kept to a maximum of 240% as the Inner of the board is an uncoated surface.

Outer Printing

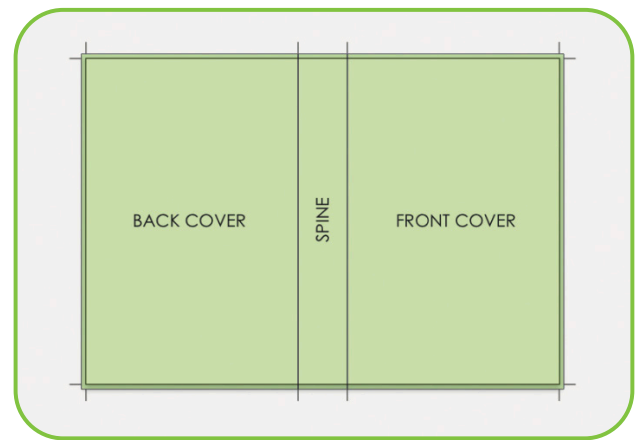

Inner Printing

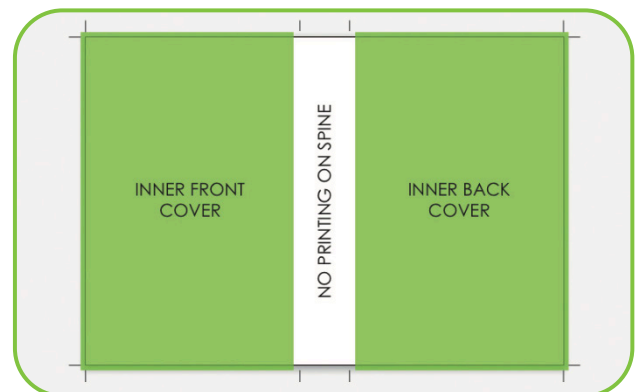

+1.5mm either side of spine (standard 2 score)
+ 3mm either side of spine (standard 4 score)

Colour Information

The colour of a finished book is obviously very important. When producing a book cover there are some rules to help achieve this.

For example: When creating a solid black panel it is useful to colour it 100% black and 50% cyan. This is known as a shiner or booster and will improve the look and density of the black panel. Without this shiner / booster it will look less rich and sometimes slightly grey.

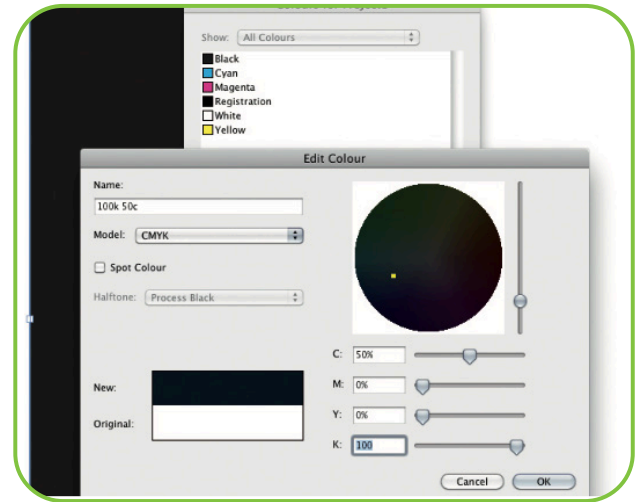

100% BLACK WITH
NO SHINER

100% BLACK WITH
50% CYAN SHINER

When designing a very rich or dark colour scheme out of all 4 process colours, it is recommended that you try to keep the maximum ink coverage below 240%. This means when you add-up the CMYK percentages it should not exceed this total. Going over this percentage could cause the inks to run, lengthens drying times and could cause problems with finishes. Ink that is not dry can also be transferred to the fore-edge of the books when trimmed in the bindery. The Registration colour should only be used for cutmarks and foldmarks.

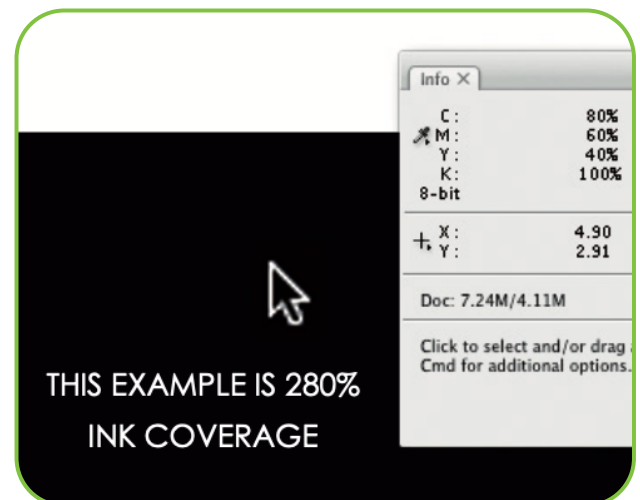

CHANGE TO 240%

INK COVERAGE TOO HEAVY
OVER 280%
LONG DRYING TIME.

Images

When creating and using cmyk or grayscale images they should be a minimum of 300dpi when in a document at 100% size. This is an industry standard and a 300dpi image will give you a good result where as a low resolution image will look blocky and pixilated.

Colour images should be supplied in CMYK and can be layered. This will sometimes change the colour of a supplied image and this is most noticeable in neon or fluorescent looking colours.

Hi Res



Low Res

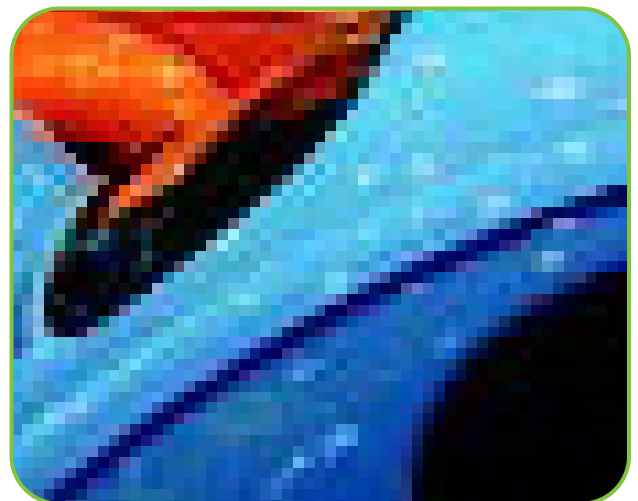

When producing or using Bitmap files they should be supplied at a maximum of 600 dpi or a minimum of 300 dpi. If creating a Bitmap from a grayscale do not convert grayscales to Bitmap Tiffs if they are lower than the specified resolution and always convert using the '50% threshold' setting.

Hi Res Bitmap Tiff



Low Res Bitmap Tiff



Finishes

At Eastbourne, the Print-On-Demand (POD) operations do not incorporate specialised finishes; instead, they offer a range of stock finishes that are complemented by lamination.

Guidelines for Cover Designers

There are certain variables that can affect components during production and though on their own they can be small, they can combine to affect the final design on the trimmed book.

It is useful therefore to follow some basic guidelines:

Type and non-bleeding images such as logos, flashes etc., should be withdrawn 4mm from book trims.

Make sure the spine size is correct for cover/cover for case.

Ensure job has both trim and spine marks and are coloured in registration. Type & logo on a spine up to 10mm needs to have a minimum clearance of 1mm to folds. This should be increased to 2mm on spines up to 30mm, then increased to 3mm on spines exceeding this.

Kiss fit images need to be spread/choked to give better fit in final printing.

Job must have a minimum of 3mm bleed for paperback and 12mm for hardback.

Make sure trim sizes are correct.

Finishing data must be supplied in CMYK.

Finishing data must fit colour area exactly.

PDF

When creating a PDF it is preferred that it is supplied with 10mm area all the way around the document. This will include cutmarks, foldmarks and the jobs bleed. Below is a PDF that is 288mm x 198mm + 10mm all round = 308mm X218mm.

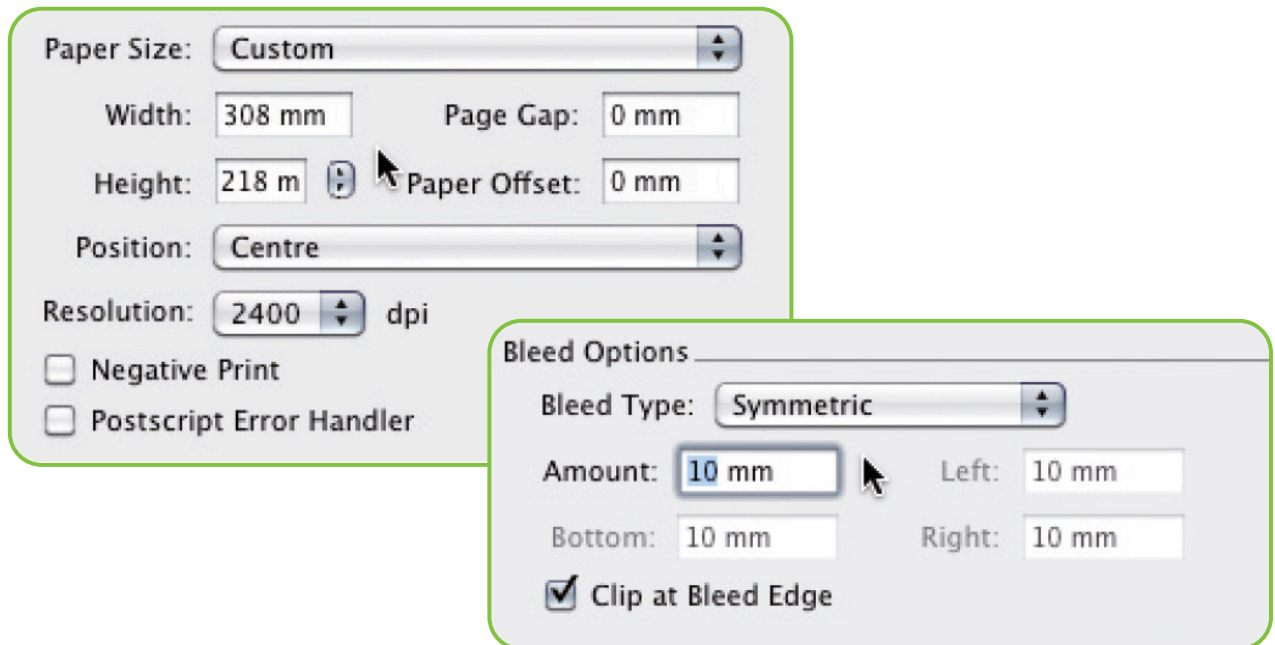

Example of a supplied cover with 10mm border all round PDF

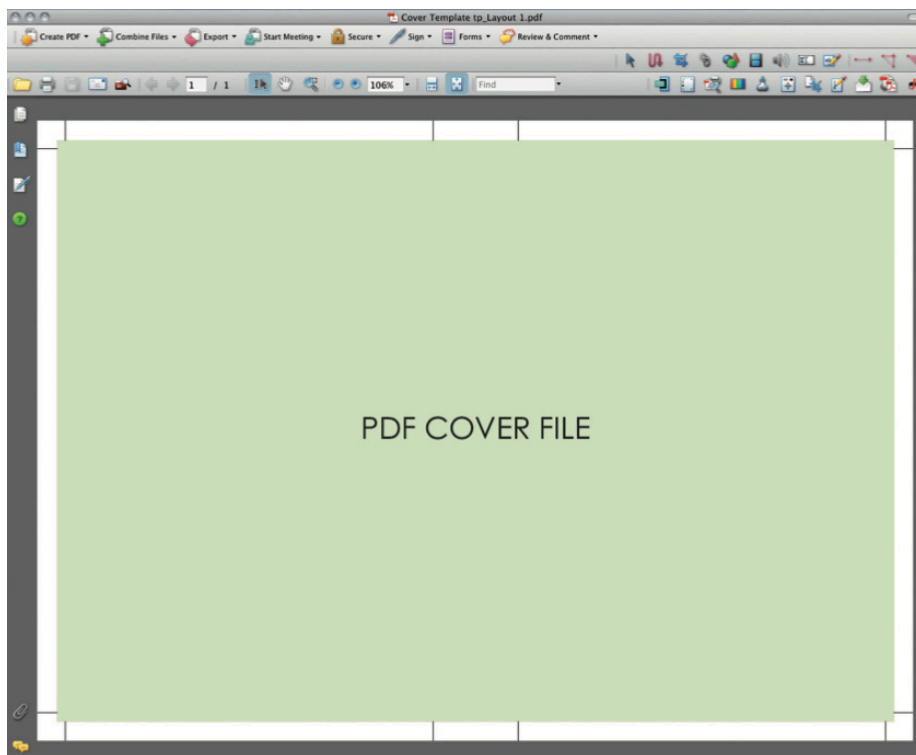

Please Note: For Print On Demand (Antony Rowe Eastbourne), transparencies must be flattened. Rips are defaulted to PDF Version 1.3 and will not support a file with transparencies on.

Fonts

Changing fonts in InDesign should be done in a specific way. The desired type should be selected and then using the tool bar select the correct font and style in the pop up menu...

The example below is the **CORRECT** way to select a font:

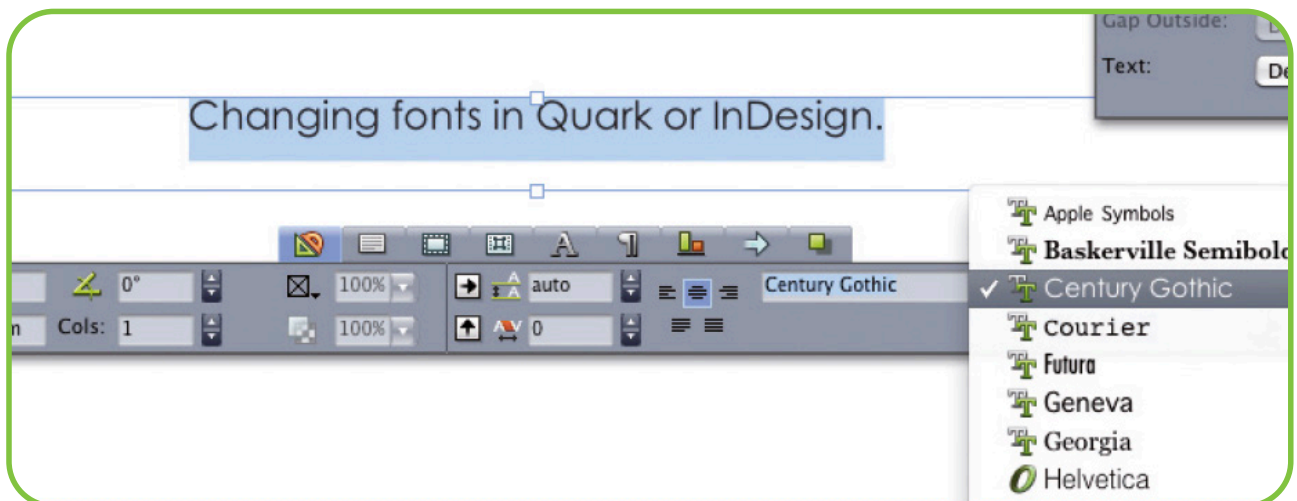

The example below is the **INCORRECT** way to select a font:

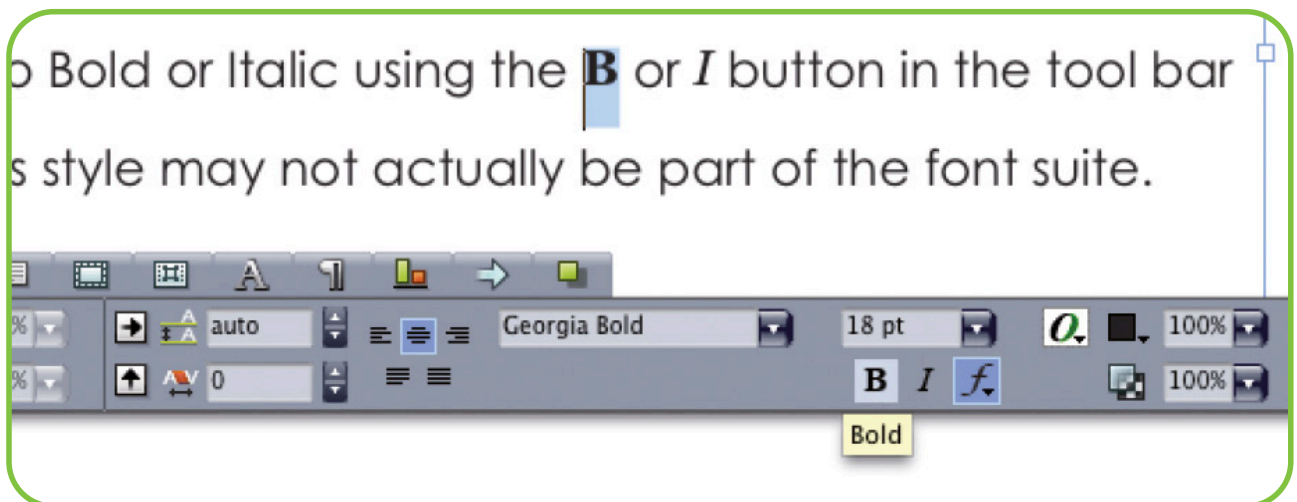

Manually forcing a font to **Bold** or *Italic* using the **B** or *I* button in the tool bar could cause problems with the type as this style may not actually be part of the font suite. Changing a font in this way will normally look ok on screen but could drop out when a print ready pdf is created. This will sometimes result in the font reverting to its normal state i.e not bold or changing to default `courier` font.

PPC Layout Details

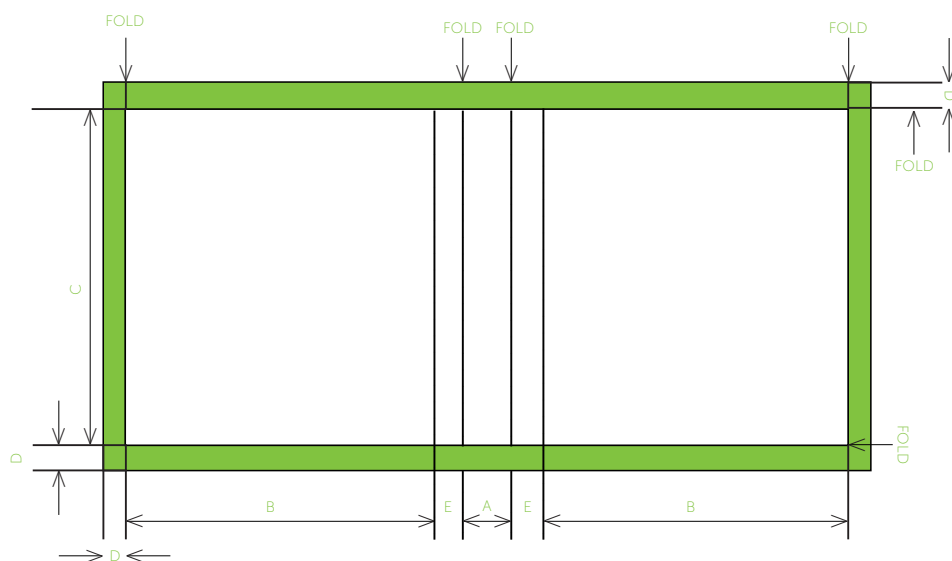

A = Square Back with 2mm Boards + 5mm

C = Trimmed page Height + 8mm

D = 20mm

E = Square Back 12mm / Round Back 8mm

B = Round & Back: Trimmed page width – 4mm
 Square Back: Trimmed page width - 4mm
 All spine widths rounded up to the nearest whole number

This area to be considered when designing/centering images on Front and Back Please discuss this with your Account Controller

Note: When using a CPI Spine Calculator, the extra in Area A for PPC is already included. Please note dimensions given for PPCs are based on the size of the hollow used to make the case, it is the publishers decision on whether the image should roll slightly to the front of the book or end on the hollow.

Paperback & flexi bind layout details

PAPERBACK LAYOUT DETAILS

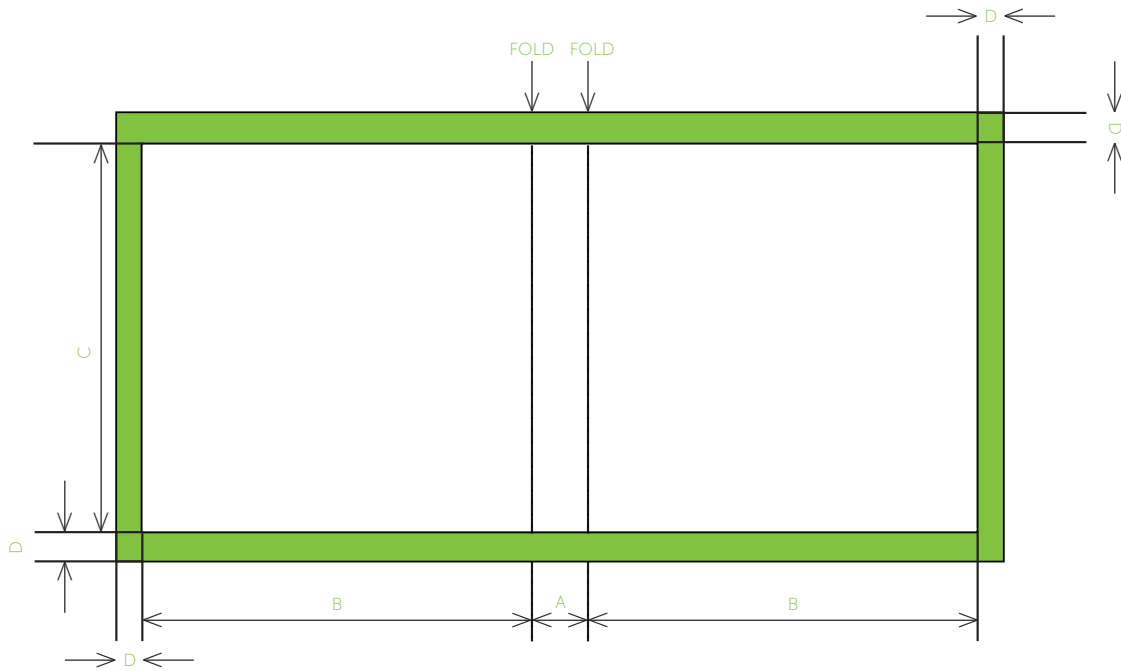

- A** = Spine Bulk
- B** = Trimmed page width
- C** = Trimmed page height
- D** = 3mm (for bleed)

FLEXI BIND LAYOUT DETAILS

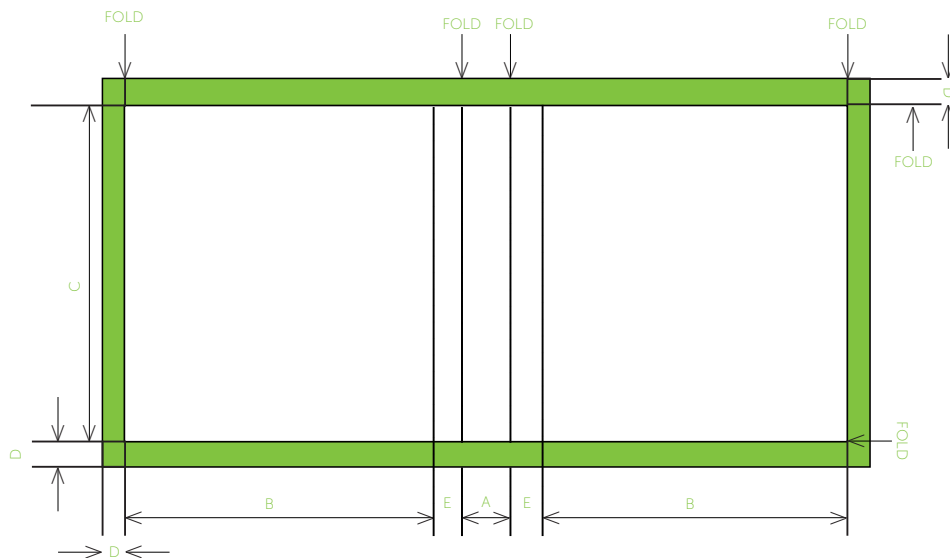

- A** = Spine Bulk + 3mm
- B** = Trimmed page width + 3mm
- C** = Trimmed page Height + 6mm
- D** = 15mm
- E** = 8mm - This area to be considered when designing/centering images Front and Back

PDF settings and samples

Available on request:

Sample of a combined CMYK PDF & Finishing

Indesign Setting for Exporting to PDF

Distiller Settings for Converting PS to PDF

CPI

CPI ANTONY ROWE (EASTBOURNE)

48-50 Birch Close,
Eastbourne, East Sussex, BN23 6PE
T: +44 (0)13 2343 4700

CPI ANTONY ROWE (BOGNOR)

Oldlands Way,
Bognor Regis PO22 9NQ
T: +44 (0)13 2343 4700